

REV	DESCRIPTION	DWG CHECK	APPR BY	APPR DATE

A-A

Logo
 PSN:model
 SW:**
 NO:drawing number
 MAX:max preload

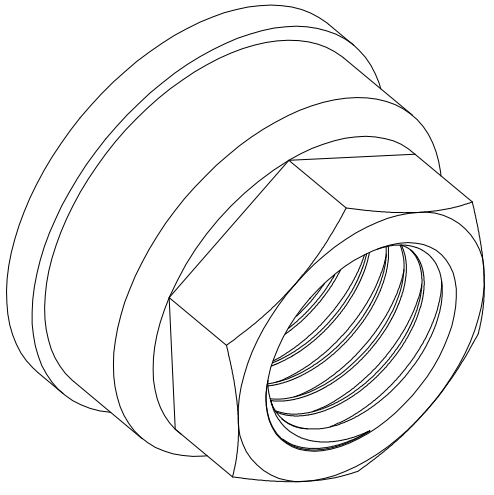
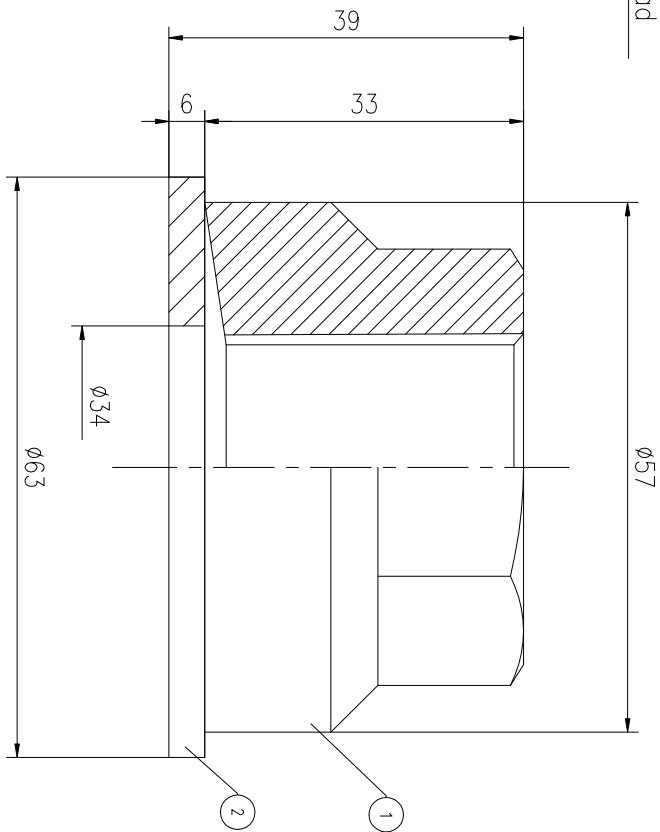
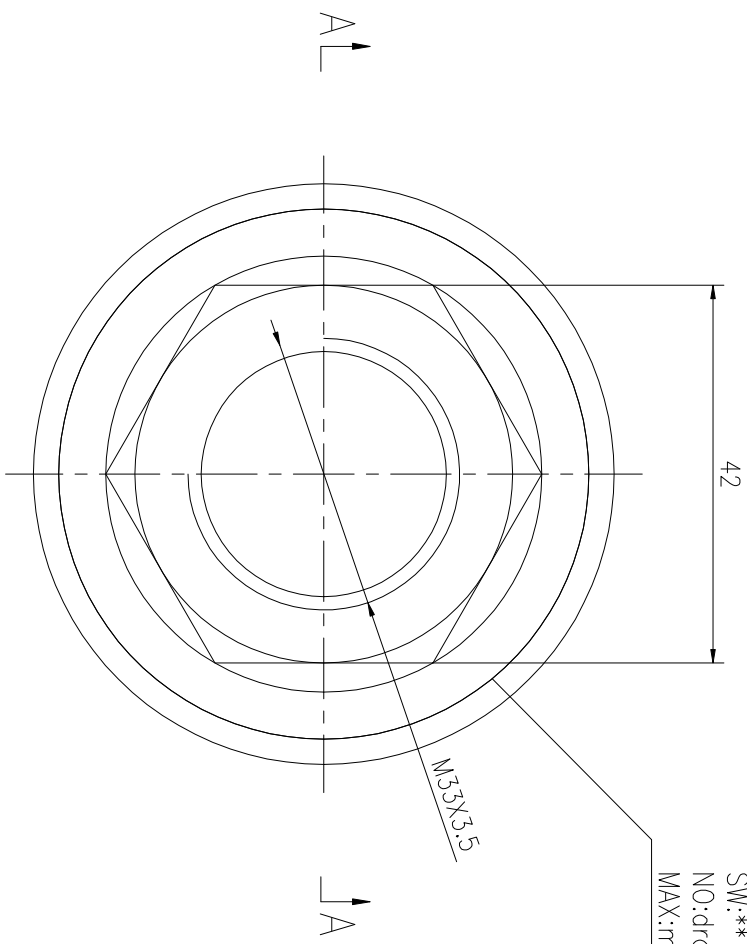

MAX PRELOAD CAPACITY	610 KN
LUBRICANT	G-N PLUS
TEMPERATURE RATING	-25 C~250 C

DESIGNED: DATE: 2025.12.01	FNH-33X3.5	DWG NO: FN333.51H	SHEET: 1:1
REVIEWED: DATE: 2025.12.01		PRELIMINARY APPROVED	

上海康普曼传动机械有限公司 +86 021-61301856
 KPM Power Transmission (Shanghai) Co.,Ltd Liang.Guo@kpmdrive.com.cn

PART	DWG NO.	QTY	DESCRIPTION	MATERIAL	WEIGHT(kg)
1	FN333.51H-1	1	Nut M33X3.5	CNMMo	0.30
2	FN333.51H-3	1	Gasket 63X34X6	CNMMo	0.10

During on-site installation, please adjust the torque in conjunction with the bolt stretching distance. Without our authorization, the drawings shall not be shared with any third party, and we reserve the right to pursue legal liability against those who disclose the drawings to external parties.