

REV	DESCRIPTION	DWG CHECK	APPR BY	APPR DATE

A-A

Logo
 PSN:model
 SW:**
 NO:drawing number
 MAX:max preload

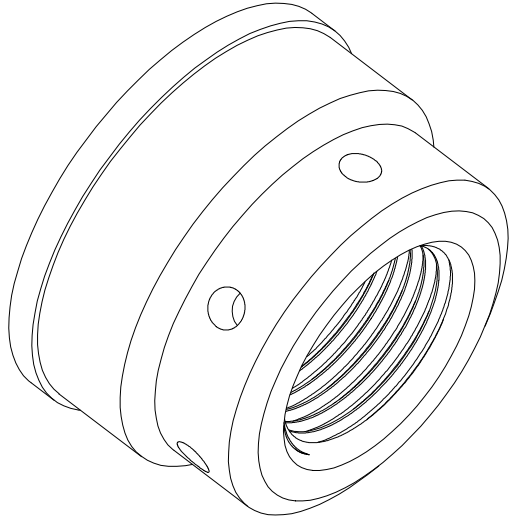
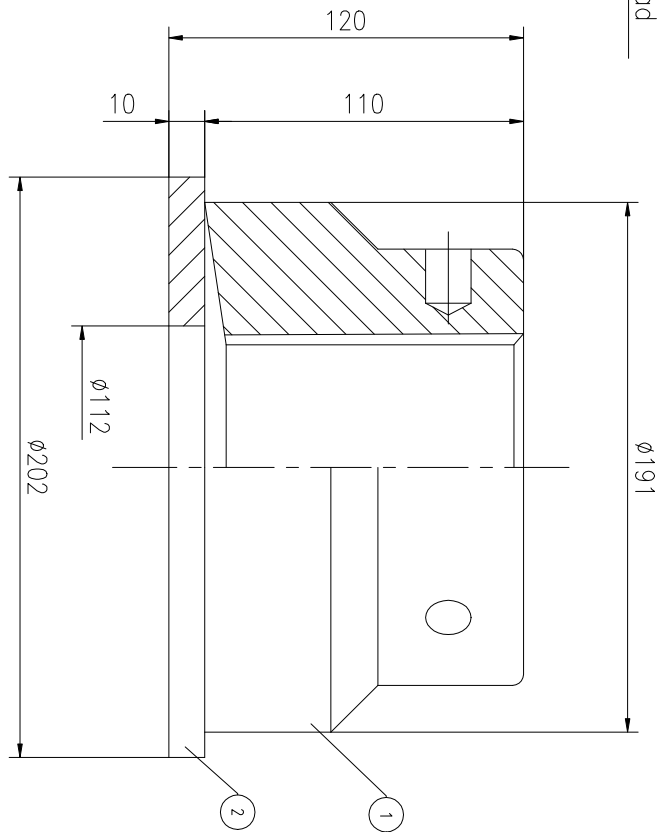
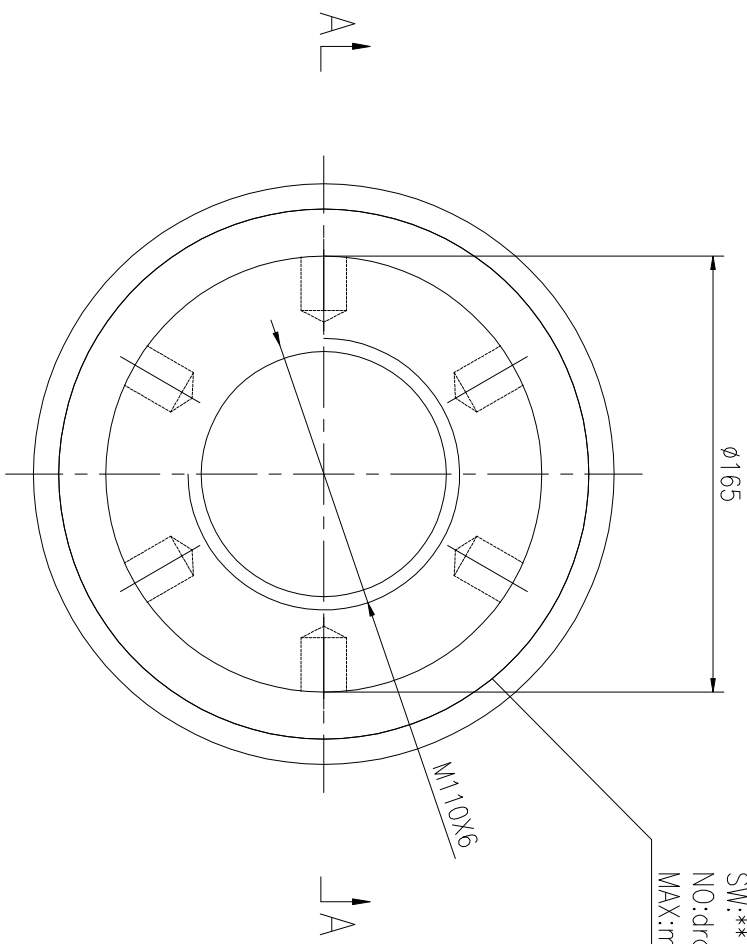

MAX PRELOAD CAPACITY	5600 KN
LUBRICANT	G-N PLUS
TEMPERATURE RATING	-25 C~250 C

PARTS LIST		PART	DWG NO.	QTY	DESCRIPTION	MATERIAL	WEIGHT(kg)
1	FN11061H-1	1	Nut M110X6	1	CNMMo	11.26	
2	FN11061H-3	1	Gasket 202X112X10	1	CNNMo	1.74	

During on-site installation, please adjust the torque in conjunction with the bolt stretching distance. Without our authorization, the drawings shall not be shared with any third party, and we reserve the right to pursue legal liability against those who disclose the drawings to external parties.

上海康普曼传动机械有限公司
 KPM Power Transmission (Shanghai) Co.,Ltd
 +86 021-61301856
 Liang.Guo@kpmdrive.com.cn

DESIGNED: DATE: 2025.12.01	FNH-110X6	DWG NO: FN11061H	SHEET: 1:1
REVIEWED: DATE: 2025.12.01			
DRAWN: DATE:			

WEIGHT: 13kg	PRELIMINARY APPROVED
STATE:	