

REV	DESCRIPTION	DWG CHECK	APPR BY	APPR DATE

A-A

Logo  
 PSN:model  
 SW:\*\*  
 NO:drawing number  
 MAX:max preload

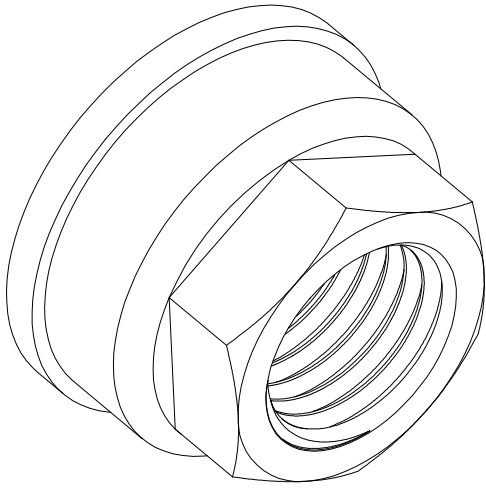
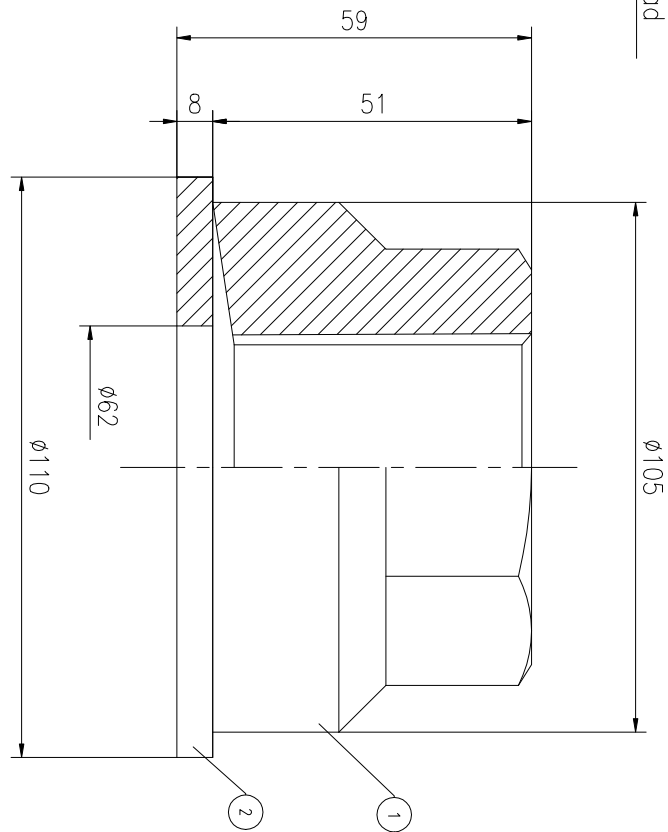
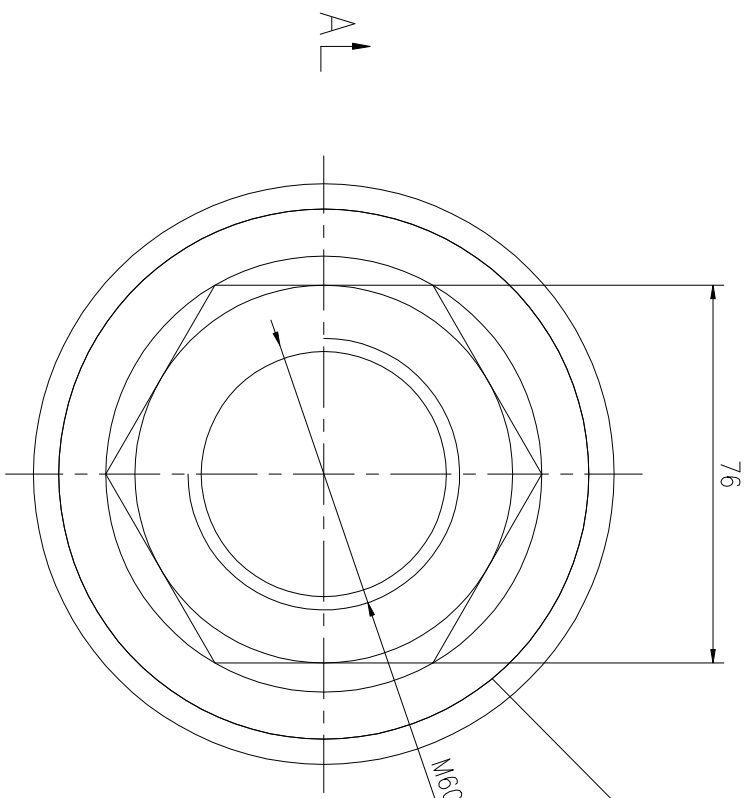

MAX PRELOAD CAPACITY	1310KN
LUBRICANT	G-N PLUS
TEMPERATURE RATING	-25 C~250 C

DESIGNED: DATE: 2025.12.01	FNM-60X5.5	DWG NO.: FN605.51M	SHEET: 1:1
REVIEWED: DATE: 2025.12.01		PRELIMINARY APPROVED	

PARTS LIST				MATERIAL	WEIGHT(kg)
PART	DWG NO.	QTY	DESCRIPTION	CNNM0	1.64
1	FN605.51M-1	1	Nut M60X5.5	CNNM0	1.64
2	FN605.51M-3	1	Gasket 110X62X8	CNNM0	0.41

During on-site installation, please adjust the torque in conjunction with the bolt stretching distance. Without our authorization, the drawings shall not be shared with any third party, and we reserve the right to pursue legal liability against those who disclose the drawings to external parties.

上海康普曼传动机械有限公司    +86 021-61301856  
 KPM Power Transmission (Shanghai) Co.,Ltd    Liang.Guo@kpmdrive.com.cn