

1-6 Ø1	>6-30 Ø2	>30-120 Ø3	>120-400 Ø4	>400-1000 Ø8
--------	----------	------------	-------------	--------------

REVISION HISTORY

REV	DESCRIPTION	DWG CHECK	APPR BY	APPR DATE

A-A

Logo  
 PSN:model  
 SW:\*\*  
 NO:drawing number  
 MAX:max preload

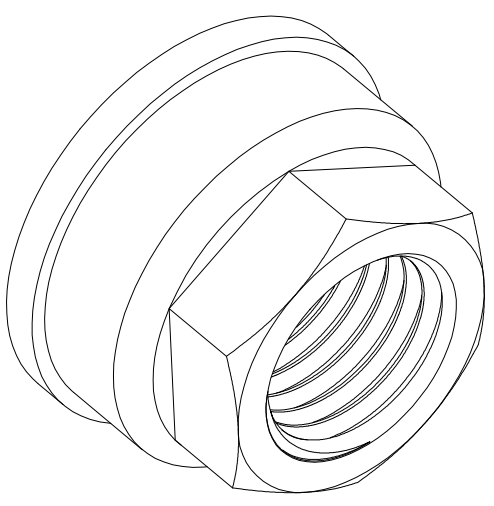
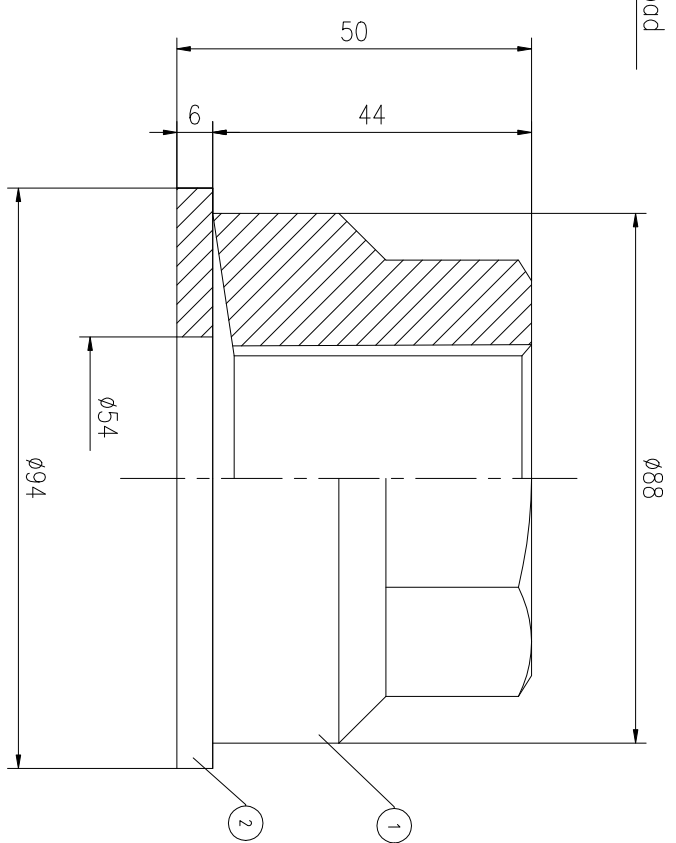
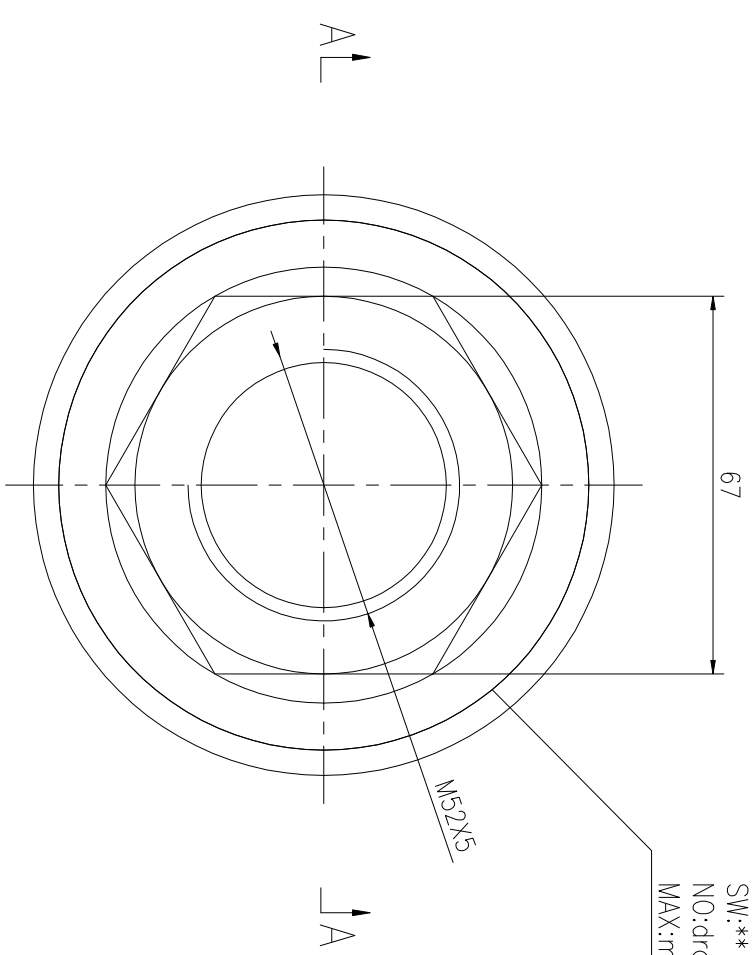

DWG NO. FN5251M SHEET: 1:1

MAX PRELOAD CAPACITY	970KN
LUBRICANT	G-N PLUS
TEMPERATURE RATING	-25 C~250 C

DESIGNED: DATE: 2025.12.01	FNM-52X5	DWG NO.: FN5251M	SHEET: 1:1
REVIEWED: DATE: 2025.12.01			
DRAWN: DATE:			

上海康普曼传动机械有限公司  
 KPM Power Transmission (Shanghai) Co.,Ltd  
 +86 021-61301856  
 Liang.Guo@kpmdrive.com.cn

PARTS LIST					
PART	DWG NO.	QTY	DESCRIPTION	MATERIAL	WEIGHT(kg)
1	FN5251M-1	1	Nut M52X5	CNMMo	1.03
2	FN5251M-3	1	Gasket 94X54X6	CNMMo	0.22

During on-site installation, please adjust the torque in conjunction with the bolt stretching distance. Without our authorization, the drawings shall not be shared with any third party, and we reserve the right to pursue legal liability against those who disclose the drawings to external parties.

WEIGHT: 1.25kg  
 STATE: PRELIMINARY APPROVED