

REV	DESCRIPTION	DWG CHECK	APPR BY	APPR DATE

A-A

Logo
 PSN:model
 SW:**
 NO:drawing number
 MAX:max preload

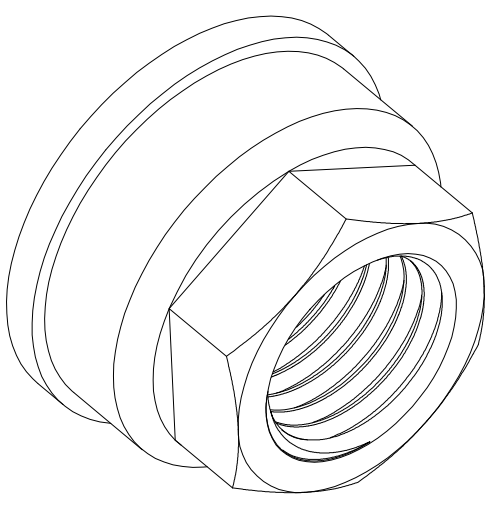
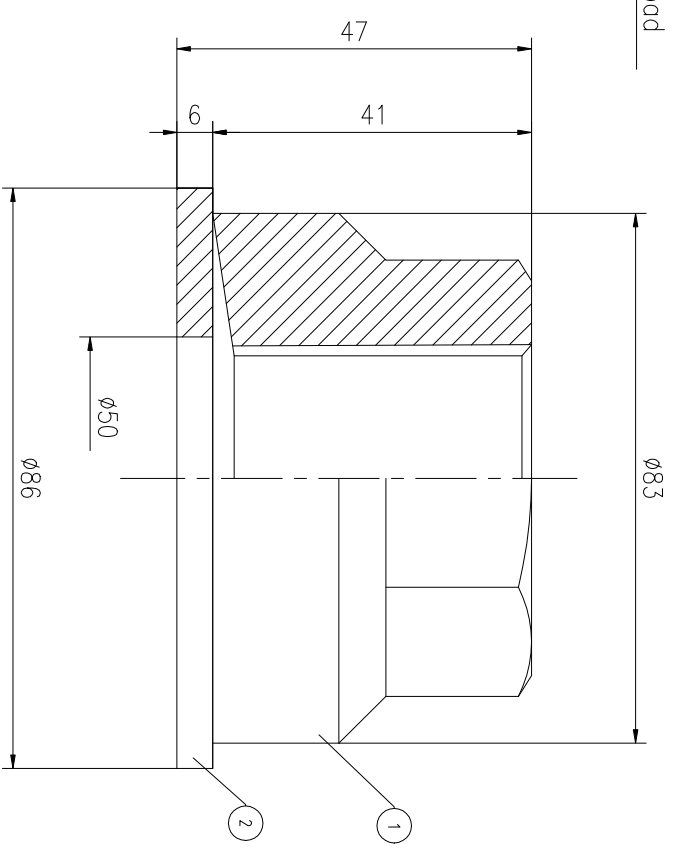
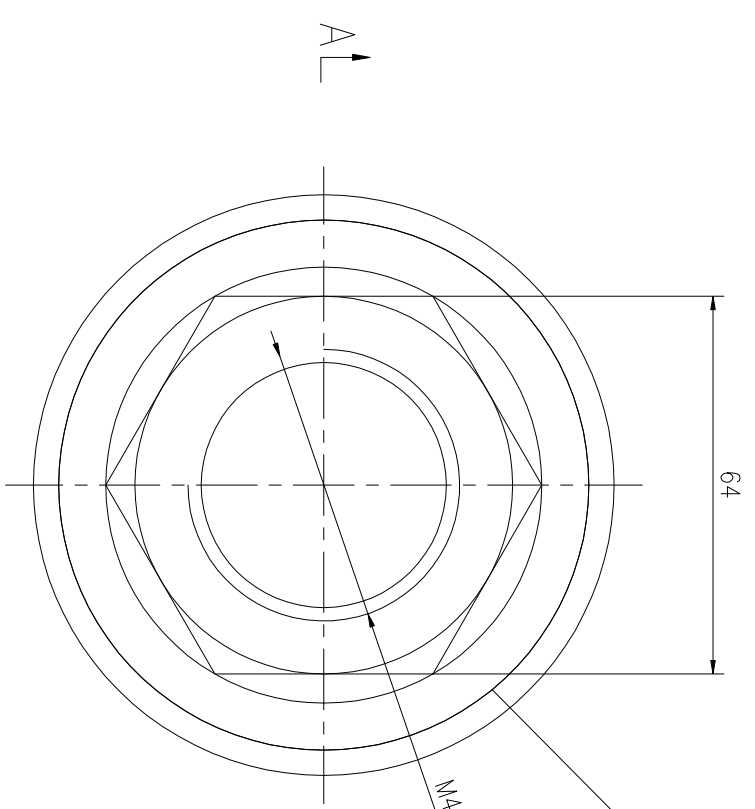

MAX PRELOAD CAPACITY	935KN
LUBRICANT	G-N PLUS
TEMPERATURE RATING	-25 C~250 C

DESIGNED: DATE: 2025.12.01	FNM-48X5	DWG NO.: FN4851M	SHEET: 1:1
REVIEWED: DATE: 2025.12.01			
DRAWN: DATE:		PRELIMINARY APPROVED	

PART	DWG NO.	QTY	DESCRIPTION	MATERIAL	WEIGHT(kg)
1	FN4851M-1	1	Nut M48X5	CNMMo	0.92
2	FN4851M-3	1	Gasket 86X50X6	CNNMo	0.18

During on-site installation, please adjust the torque in conjunction with the bolt stretching distance. Without our authorization, the drawings shall not be shared with any third party, and we reserve the right to pursue legal liability against those who disclose the drawings to external parties.

上海康普曼传动机械有限公司
 KPM Power Transmission (Shanghai) Co.,Ltd
 +86 021-61301856
 Liang.Guo@kpmdrive.com.cn