

REV	DESCRIPTION	DWG CHECK	APPR BY	APPR DATE

A-A

Logo
 PSN:model
 SW:**
 NO:drawing number
 MAX:max preload

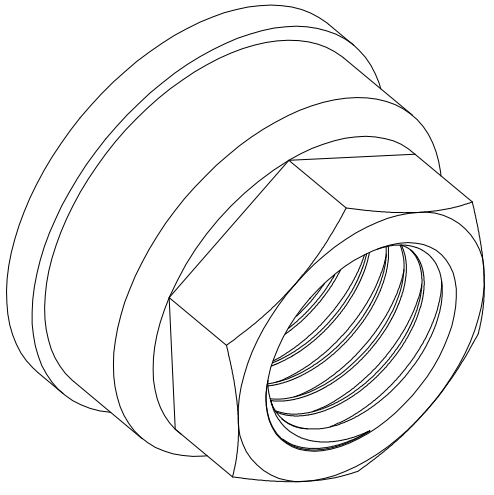
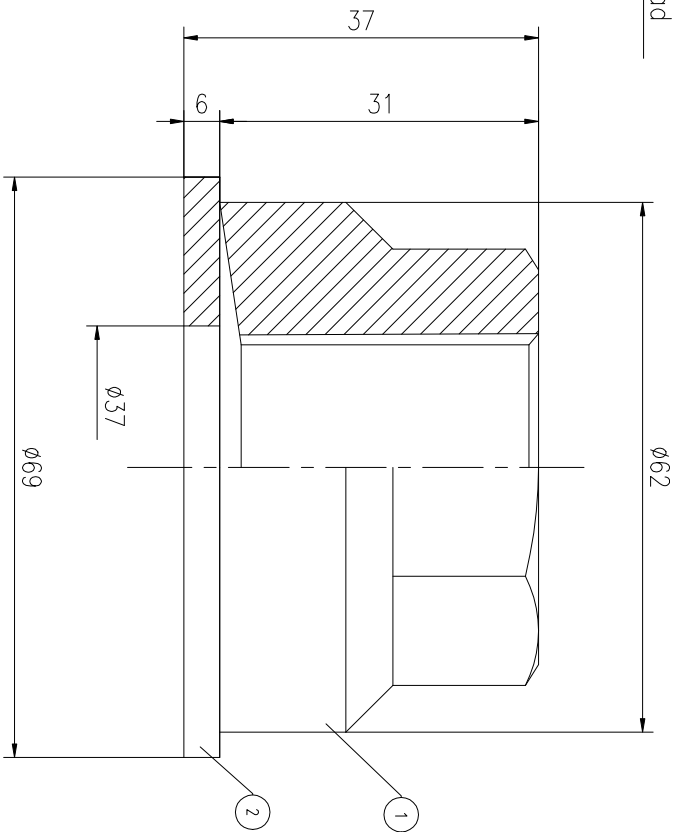
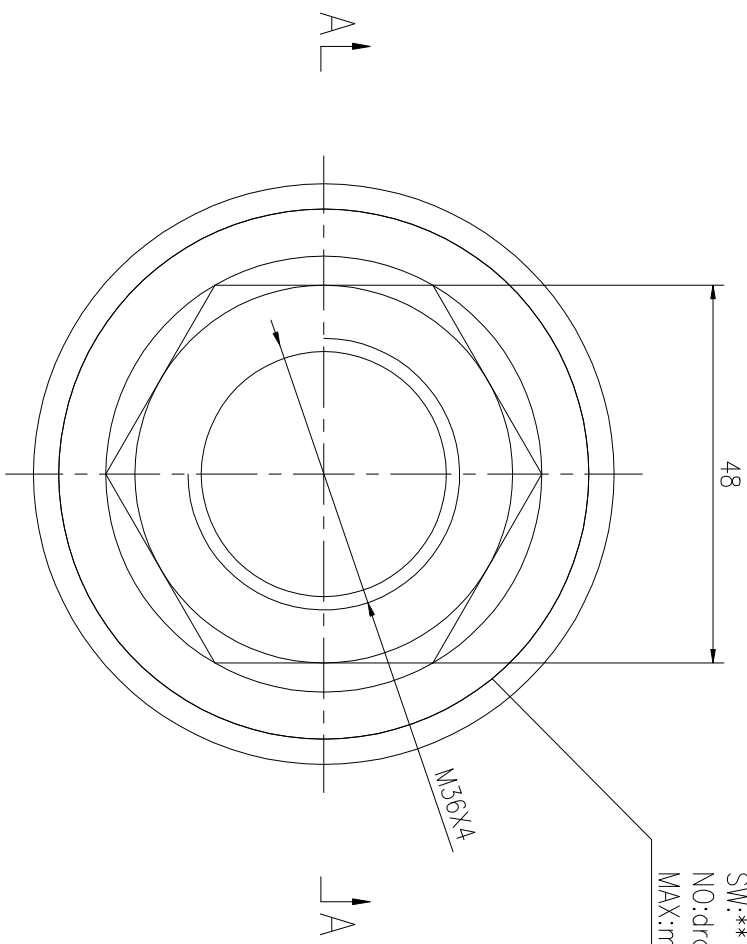

MAX PRELOAD CAPACITY	460KN
LUBRICANT	G-N PLUS
TEMPERATURE RATING	-25 C~250 C

PART	DWG NO.	QTY	DESCRIPTION	MATERIAL	WEIGHT(kg)
1	FN3641M-1	1	Nut M36X4	CNMMo	0.37
2	FN3641M-3	1	Gasket 69X37X6	CNNMo	0.13

During on-site installation, please adjust the torque in conjunction with the bolt stretching distance. Without our authorization, the drawings shall not be shared with any third party, and we reserve the right to pursue legal liability against those who disclose the drawings to external parties.

上海康普曼传动机械有限公司
 KPM Power Transmission (Shanghai) Co.,Ltd
 +86 021-61301856
 Liang.Guo@kpmdrive.com.cn

DESIGNED: DATE: 2025.12.01
 REVIEWED: DATE: 2025.12.01
 DRAWN: DATE:

DWG NO: FN3641M SHEET: 1:1

MAX PRELOAD CAPACITY: 460KN
 LUBRICANT: G-N PLUS
 TEMPERATURE RATING: -25 C~250 C

PRELIMINARY APPROVED