

A-A

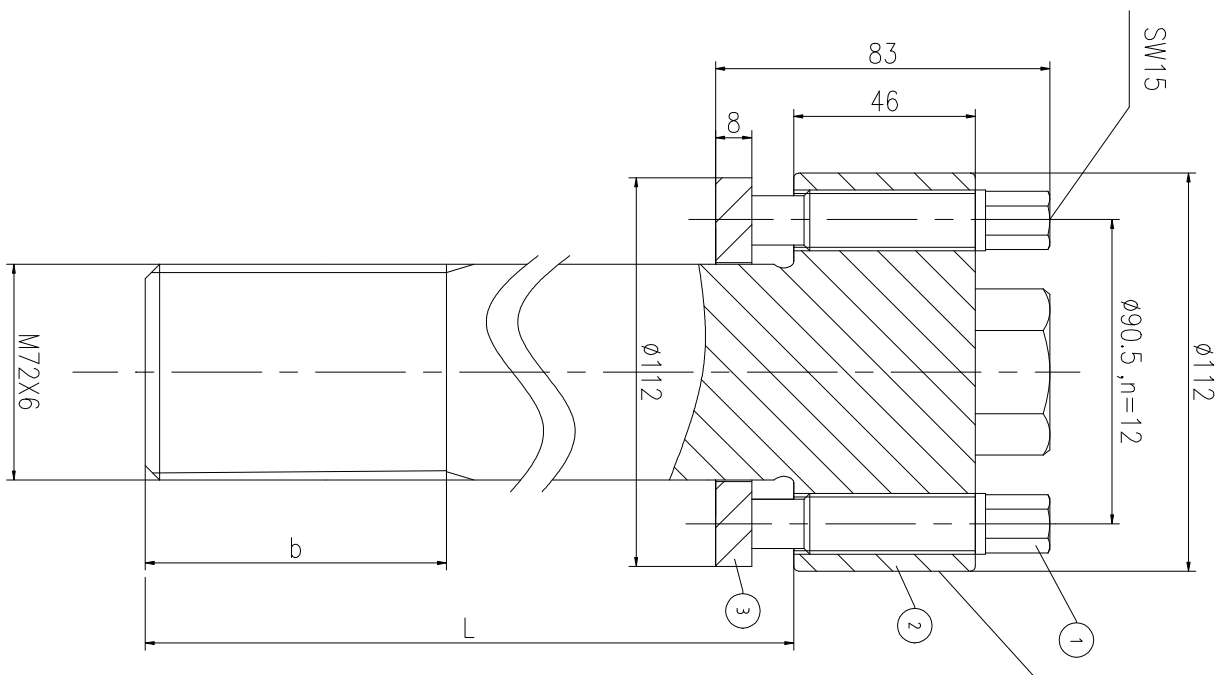

Logo
 PSN:model
 NO: drawing number
 NOM torque:**
 NOM preload:**
 MAX:max preload

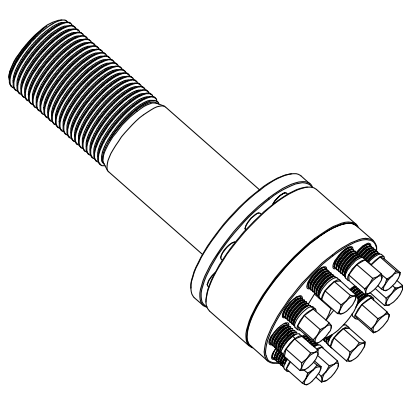
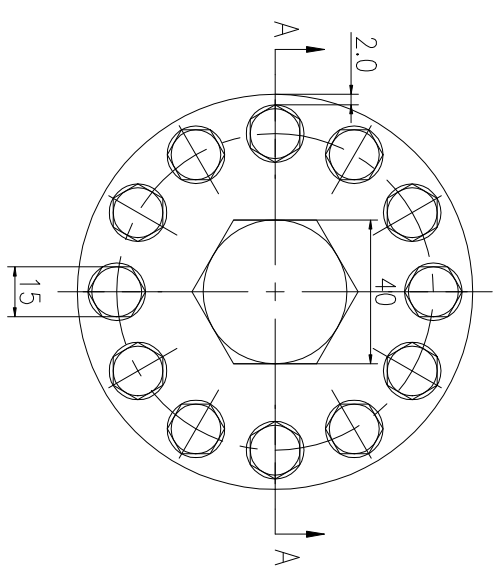

PARTS LIST

PART	DWG NO.	QTY	DESCRIPTION	MATERIAL	WEIGHT(kg)
1	BBS17.516751	12	Bolt 11/16-16UN-75	CNMMo	0.14 / pcs
2	BS72661H-1	1	S-BOLT M72X6	CNMMo	/
3	BS72661H-3	1	Gasket 72.5X112X8	CNMMo	0.36

During on-site installation, please adjust the torque in conjunction with the bolt stretching distance. Without our authorization, the drawings shall not be shared with any third party, and we reserve the right to pursue legal liability against those who disclose the drawings to external parties.

上海康普曼传动机械有限公司
 KPM Power Transmission (Shanghai) Co.,Ltd
 +86 021-61301856

NOM TORQUE	303 NM	DESIGNED:	DATE:	2025.12.02	DWG NO.:	BS72661H	SHEET:	1:1
NOM PRELOAD	1640 KN	REVIEWED:	DATE:	2025.12.02	DWG NO.:	BS72661H	SHEET:	1:1
MAX PRELOAD CAPACITY	1690 KN	TEMPERATURE RATING	-25 C~250 C					
LUBRICANT	G-N PLUS	PRELIMINARY APPROVED						

The dimensions at B and L positions are tailored to the customer's specific requests

REV	DESCRIPTION	DWG CHECK	APPR BY	APPR DATE