

Unmarked tolerances shall be implemented in accordance with ISO 2768-mk.				
1-6 0:1	>6-30 0:2	>30-120 0:3	>120-400 0:5	>400-1000 0:8

		REVISION HISTORY		
REV	DESCRIPTION	DWG CHECK	APPR BY	APPR DATE

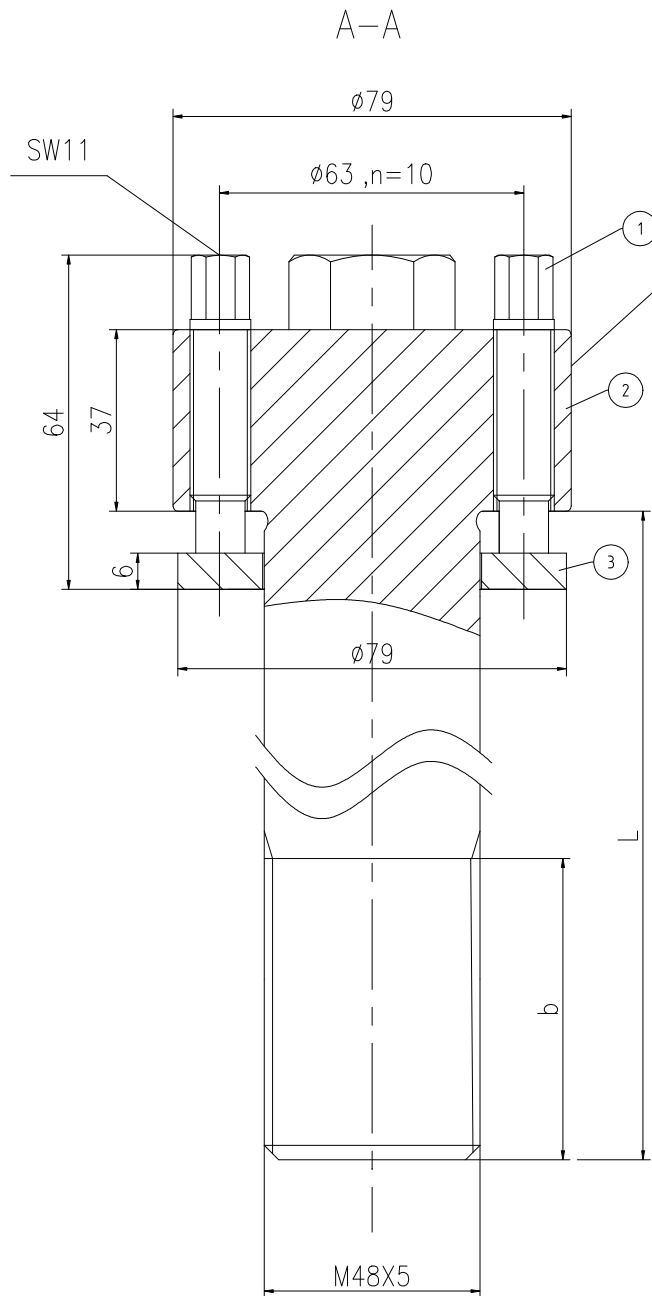

Logo
 PSN:model
 NO:drawing number
 NOM torque:**
 NOM preload:**
 MAX:max preload

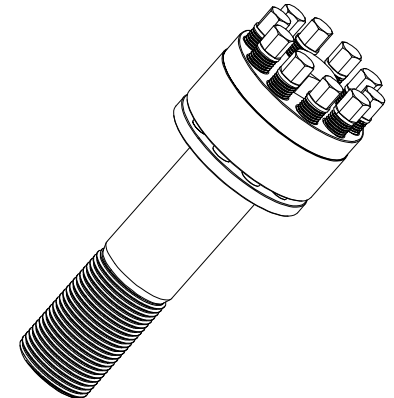
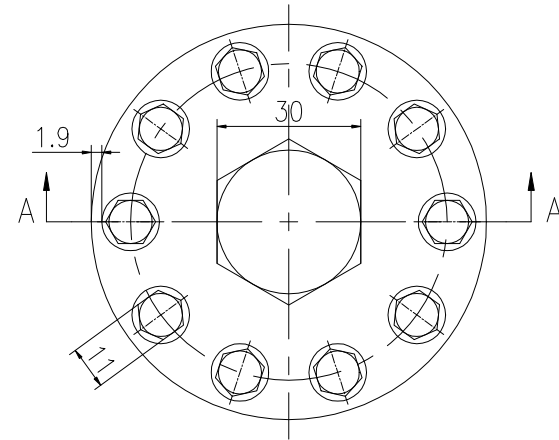

PARTS LIST					
PART	DWG NO.	QTY	DESCRIPTION	MATERIAL	WEIGHT(kg)
1	BBS12.720581	10	Bolt 1/2-20UNF-58	CrNiMo	0.06 /pcs
2	BS48551H-1	1	S-BOLT M48X5	CrNiMo	/
3	BS48551H-3	1	Gasket 48.5X79X6	CrNiMo	0.14

During on-site installation, please adjust the torque in conjunction with the bolt stretching distance. Without our authorization, the drawings shall not be shared with any third party, and we reserve the right to pursue legal liability against those who disclose the drawings to external parties.

NOM TORQUE	133 NM
NOM PRELOAD	800 KN
MAX PRELOAD CAPACITY	855 KN
LUBRICANT	G-N PLUS
TEMPERATURE RATING	-25 C~250 C

上海康普曼传动机械有限公司		+86 021-61301856	
KPM Power Transmission (Shanghai) Co.,Ltd		Liang.Guo@kpmdrive.com.cn	
DESIGNED: DAYE:	2025.12.02	BSH-48X5	WEIGHT: /kg
REVIEWED: DAYE:	2025.12.02		STATE:
DRAWN: DAYE:		DWG NO: BS48551H	SHEET: 1:1
PRELIMINARY APPROVED			

The dimensions at B and L positions are tailored to the customer's specific requests

DWG NO: BS48551H
 SHEET: 1:1