

A-A

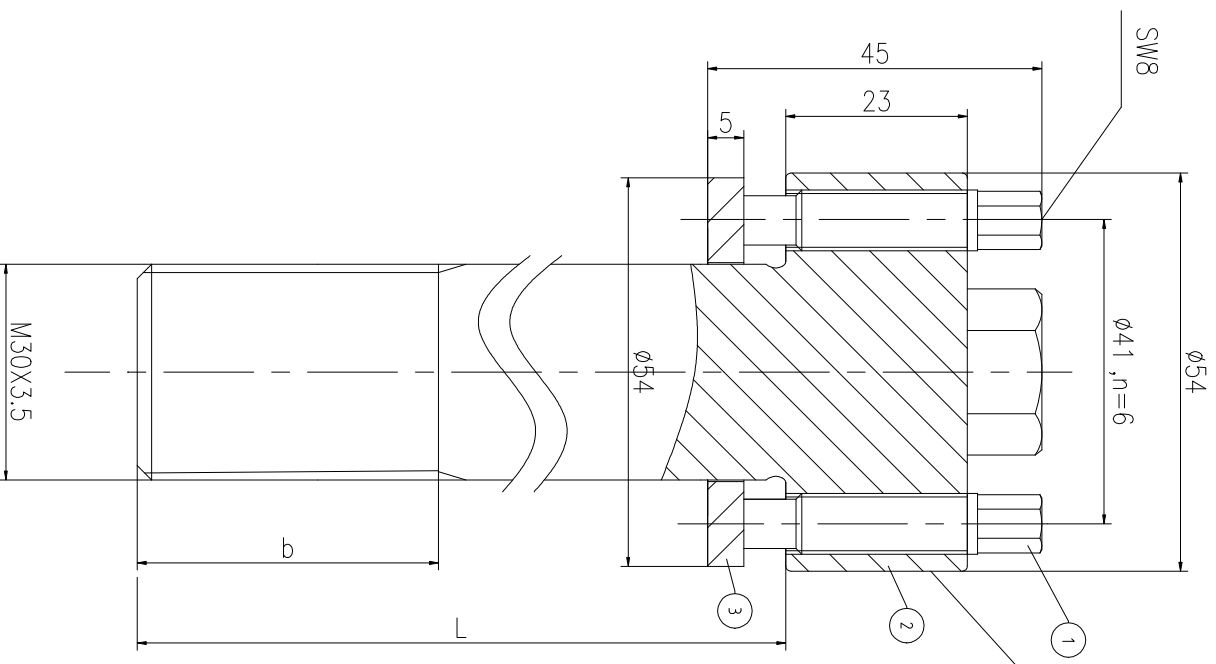

Logo
 PSN:model
 NO:drawing number
 NOM torque:**
 NOM preload:**
 MAX:max preload

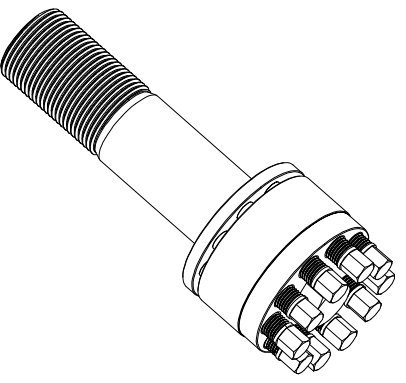
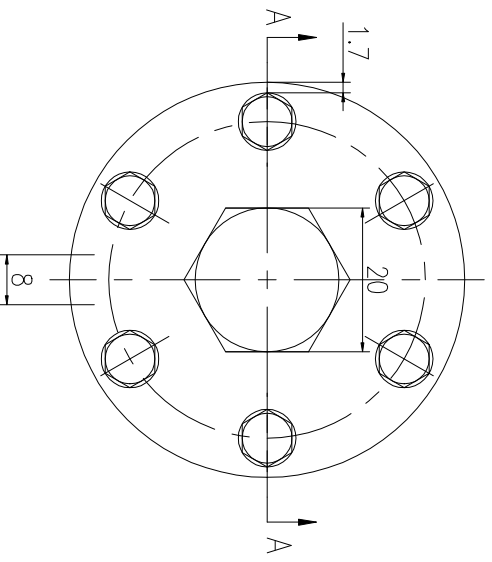

PARTS LIST

PART	DWG NO.	QTY	DESCRIPTION	MATERIAL	WEIGHT(kg)
1	BS303.531M-1	6	Bolt 3/8-20UNF-40	CNMMo	0.02 / pcs
2	BS303.531M-3	1	S-BOLT M30X3.5	CNMMo	/
3	BS303.531M-3	1	Gasket 30.5X54X5	CNMMo	0.08

During on-site installation, please adjust the torque in conjunction with the bolt stretching distance. Without our authorization, the drawings shall not be shared with any third party, and we reserve the right to pursue legal liability against those who disclose the drawings to external parties.

上海康普曼传动机械有限公司 +86 021-61301856

KPM Power Transmission (Shanghai) Co.,Ltd Liang.Guo@kpmdrive.com.cn

NOM TORQUE	43 NM
NOM PRELOAD	214 KN
MAX PRELOAD CAPACITY	286 KN
LUBRICANT	G-N PLUS
TEMPERATURE RATING	-25 C~250 C

The dimensions at B and L positions are tailored to the customer's specific requests

REV	DESCRIPTION	DWG CHECK	APPR BY	APPR DATE

DESIGNED: DATE: 2025.12.02	BSM-30X3.5	DWG NO: BS303.531M	SHEET: 1/1
REVIEWED: DATE: 2025.12.02			
DRAWN: DATE:			
			PRELIMINARY APPROVED