

A-A

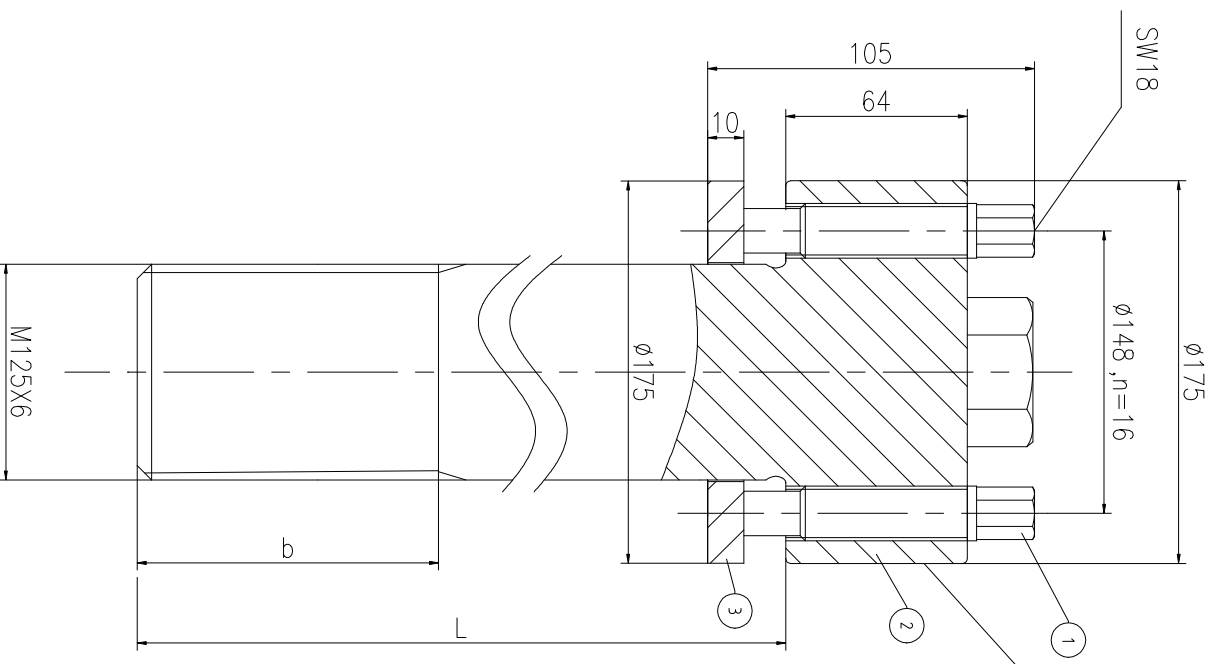

Logo
 PSN:model
 NO: drawing number
 NOM torque:**
 NOM preload:**
 MAX:max preload

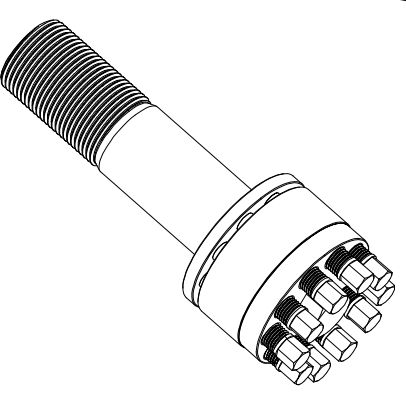
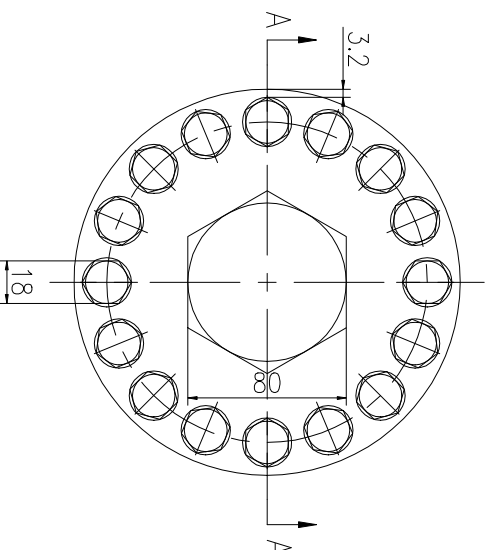

PARTS LIST

PART	DWG NO.	QTY	DESCRIPTION	MATERIAL	WEIGHT(kg)
1	BS20.616951	16	Bolt 13/16-16UN-95	CNMMo	0.25 / pcs
2	BS1256381M-1	1	S-BOLT M125X6	CNMMo	/
3	BS1256381M-3	1	Gasket 125.5X175X10	CNMMo	0.92

During on-site installation, please adjust the torque in conjunction with the bolt stretching distance. Without our authorization, the drawings shall not be shared with any third party, and we reserve the right to pursue legal liability against those who disclose the drawings to external parties.

上海康普曼传动机械有限公司

KPM Power Transmission (Shanghai) Co.,Ltd
 Liang.Guo@kpmdrive.com.cn

NOM TORQUE	586 NM
NOM PRELOAD	3650 KN
MAX PRELOAD CAPACITY	4880 KN
LUBRICANT	G-N PLUS
TEMPERATURE RATING	-25 C~250 C

DESIGNED: DATE: 2025.12.02	BSM-125X6	DWG NO.: BS1256381M	SHEET: 1:1
REVIEWED: DATE: 2025.12.02			
KPM Power Transmission (Shanghai) Co.,Ltd		PRELIMINARY APPROVED	

The dimensions at B and L positions are tailored to the customer's specific requests

REV	DESCRIPTION	DWG CHECK	APPR BY	APPR DATE

REVISION HISTORY