

REV	DESCRIPTION	DESIGN CHECK	APPR BY	APPR DATE

REVISION HISTORY

Logo
 PSN:model
 NO:drawing number
 NOM torque:**
 NOM preload:**
 MAX:max preload

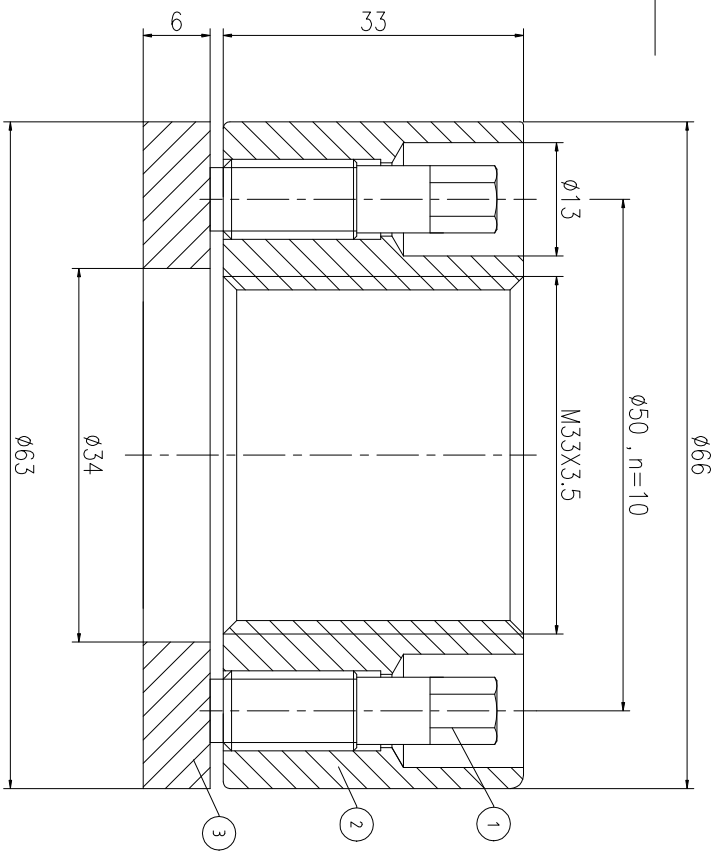
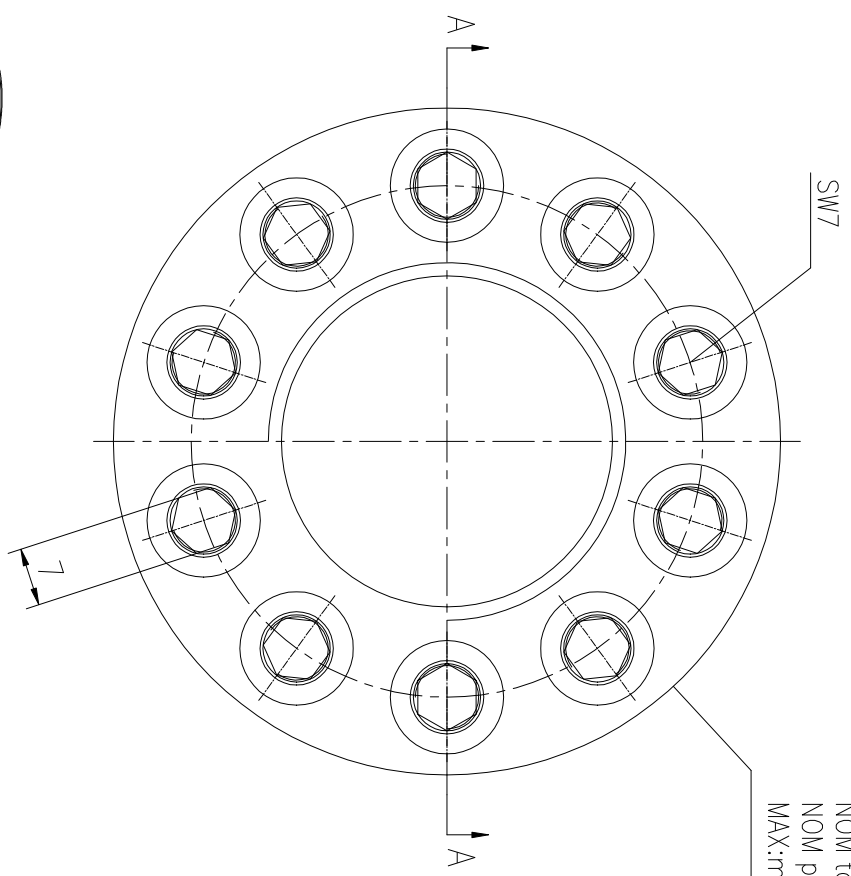

PARTS LIST

PART	DWG NO.	QTY	DESCRIPTION	MATERIAL	WEIGHT(kg)
1	BCHH9.520291	10	Bolt 3/8-20UNF-29	CNiMn	0.01 / pcs
2	CHH10.551M-1	1	NUT M33X3.5	CNiMn	0.55
3	CHH10.551M-3	1	Gasket 34X63X6	CNiMn	0.10

During on-site installation, please adjust the torque in conjunction with the bolt stretching distance. Without our authorization, the drawings shall not be shared with any third party, and we reserve the right to pursue legal liability against those who disclose the drawings to external parties.

上海康普曼传动机械有限公司
 KPM Power Transmission (Shanghai) Co., Ltd
 +86 021-61301856
 Liong Guo@kpmdrive.com.cn

NOM TORQUE	31 NM
NOM PRELOAD	260 KN
MAX PRELOAD CAPACITY	340 KN
LUBRICANT	G-N PLUS
TEMPERATURE RATING	-25 C~250 C

