

Logo
 PSN:model
 NO:drawing number
 NOM torque:**
 NOM preload:**
 MAX:max preload

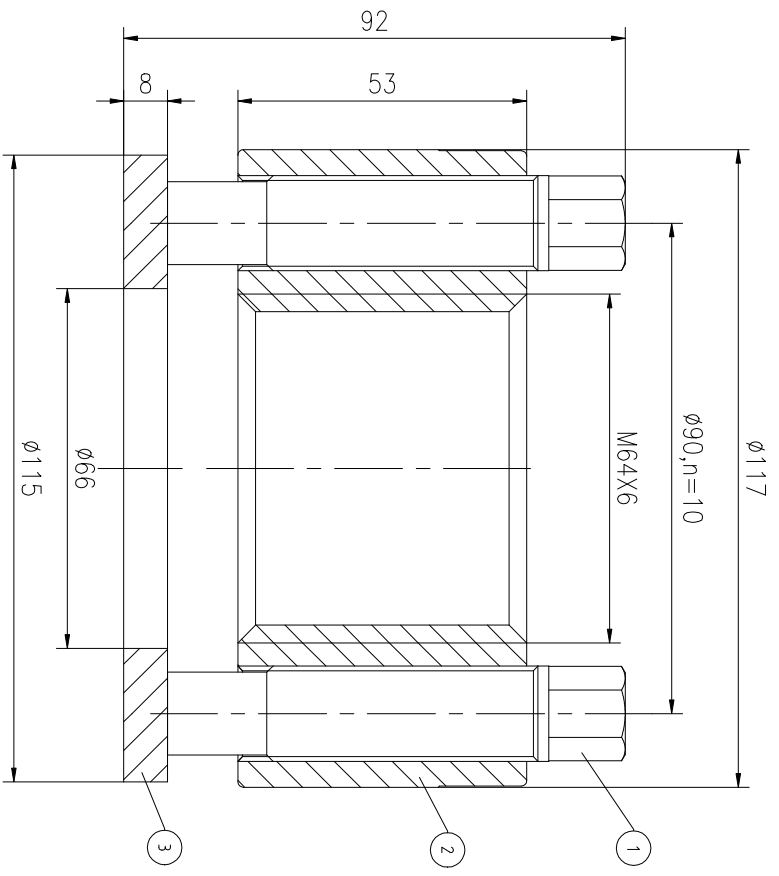
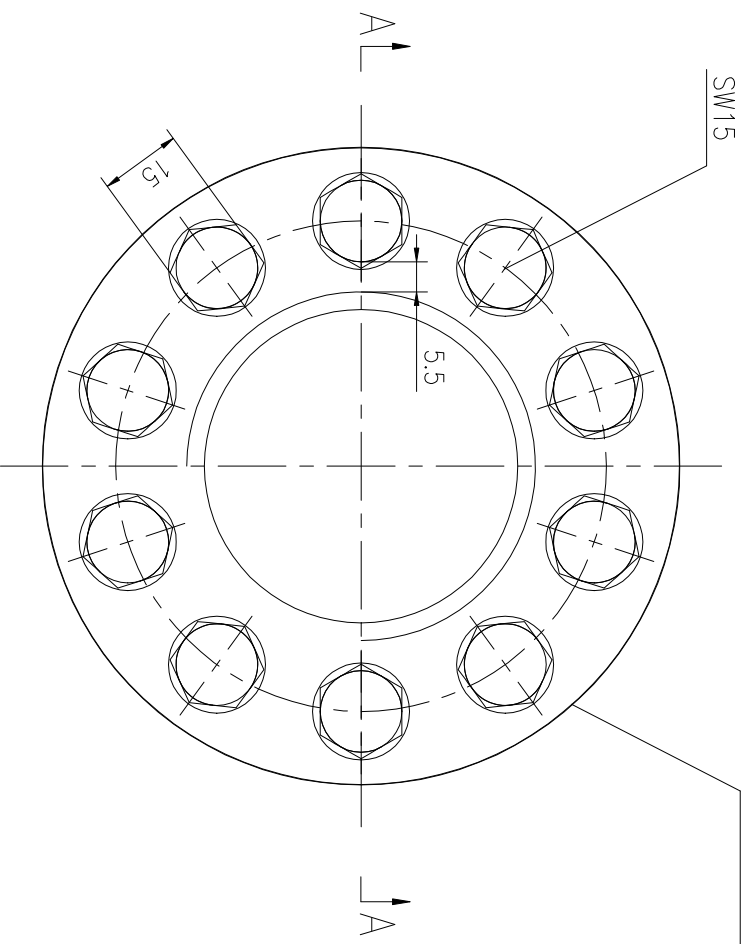

PARTS LIST

PART	DWG NO.	QTY	DESCRIPTION	MATERIAL	WEIGHT(kg)
1	BAS17.516841	10	Bolt 11/16-16UN-84	CNMMo	0.16/pcs
2	AS64651H-1	1	Nut M6X6	CNMMo	2.32
3	AS64651H-3	1	Gasket 66X115X8	CNMMo	0.44

During on-site installation, please adjust the torque in conjunction with the bolt stretching distance. Without our authorization, the drawings shall not be shared with any third party, and we reserve the right to pursue legal liability against those who disclose the drawings to external parties.

NOM TORQUE	352NM	上海康普曼传动机械有限公司	+86 021-61301856
NOM PRELOAD	1580KN	KPM Power Transmission (Shanghai) Co.,Ltd	Liang.Guo@kpmdrive.com.cn
MAX PRELOAD CAPACITY	2100KN	DESIGNED: 2025.11.03	ASH-64X6
LUBRICANT	G-N PLUS	REVIEWED: 2025.11.03	DWG NO.: AS64651H
TEMPERATURE RATING	-25 C~250 C	DRAWN: 2025.11.03	SHEET: 1:1

