

REV	DESCRIPTION	DWG CHECK	APPR BY	APPR DATE

REVISION HISTORY

Logo
 PSN:model
 NO:drawing number
 NOM torque:**
 NOM preload:**
 MAX:max preload

A-A

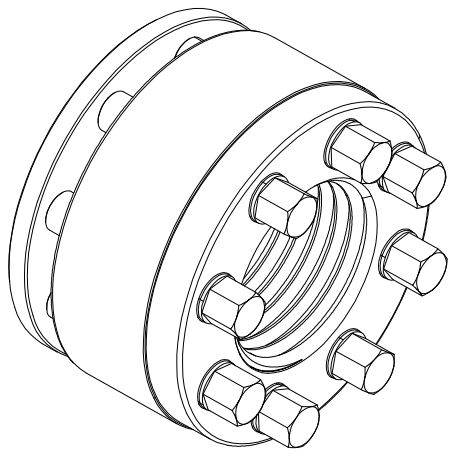
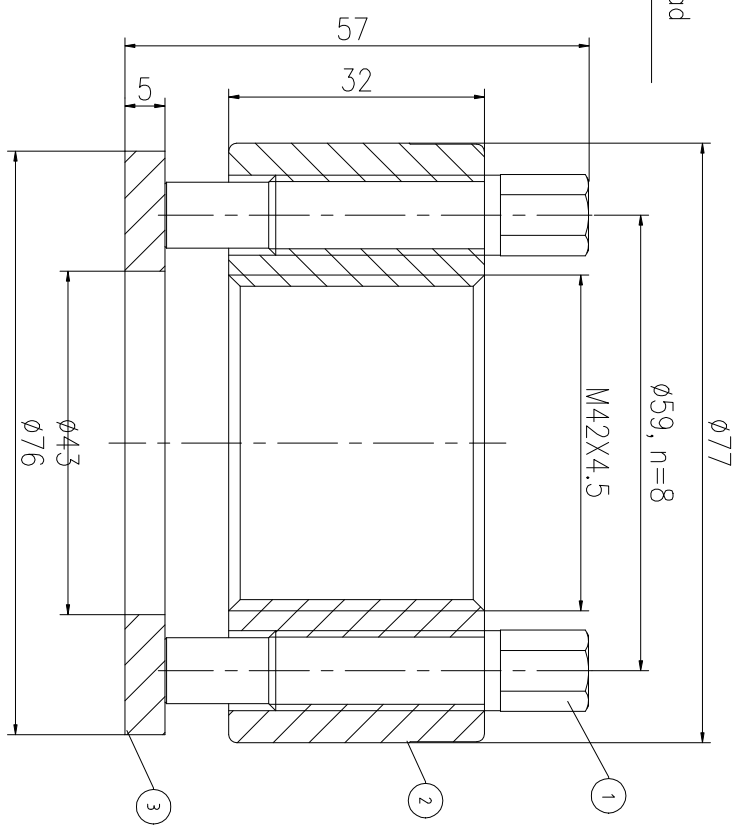
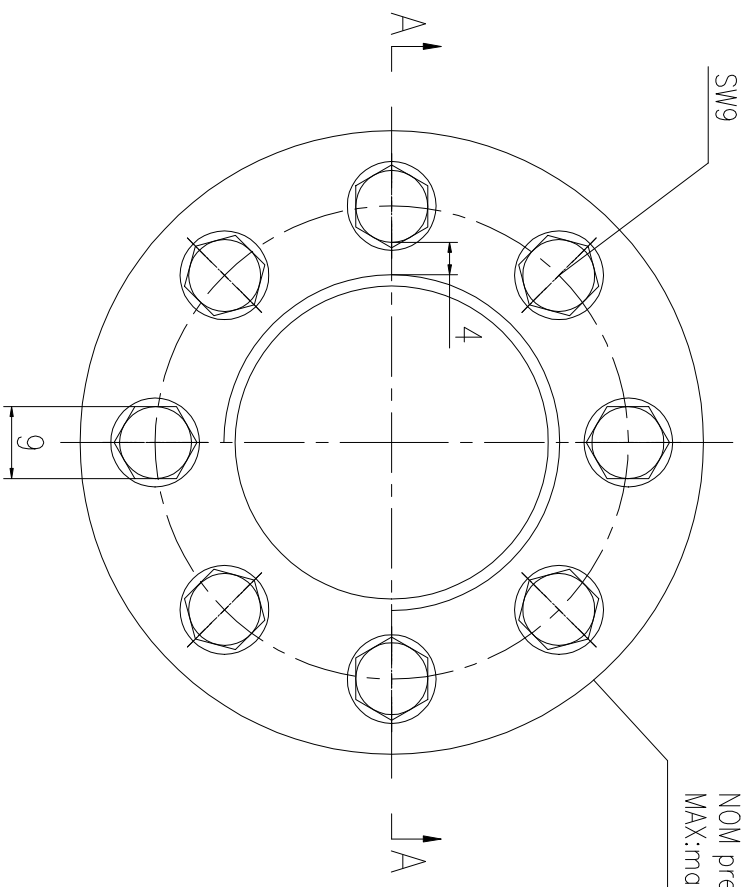

PARTS LIST		PART	DWG NO.	QTY	DESCRIPTION	MATERIAL	WEIGHT(kg)
1	BAS11.120523	8	Bolt 7/16-20UNF	CNMMo	0.04/pcs		
2	AS424.541M-1	1	Nut M42X4.5	CNMMo	0.67		
3	AS424.541M-3	1	Gasket 43X76X5	CNMMo	0.12		

During on-site installation, please adjust the torque in conjunction with the bolt stretching distance. Without our authorization, the drawings shall not be shared with any third party, and we reserve the right to pursue legal liability against those who disclose the drawings to external parties.

NOM TORQUE	80NM	上海康普曼传动机械有限公司	+86 021-61301856
NOM PRELOAD	457KN	KPM Power Transmission (Shanghai) Co.,Ltd	Liang.Guo@kpmdrive.com.cn
MAX PRELOAD CAPACITY	610KN	DESIGNED: 2025.11.06	ASM-42X4.5
LUBRICANT	G-N PLUS	REVIEWED: 2025.11.06	DWG NO.: AS424.541M
TEMPERATURE RATING	-25 C~250 C	DRAWN: 2025.11.06	SHEET: 1:1

WEIGHT: 1.1kg
 STATE: PRELIMINARY APPROVED