

REV	DESCRIPTION	DWG CHECK	APPR BY	APPR DATE

REVISION HISTORY

Logo
 PSN:model
 NO:drawing number
 NOM torque:**
 NOM preload:**
 MAX:max preload

A-A
 Ø194

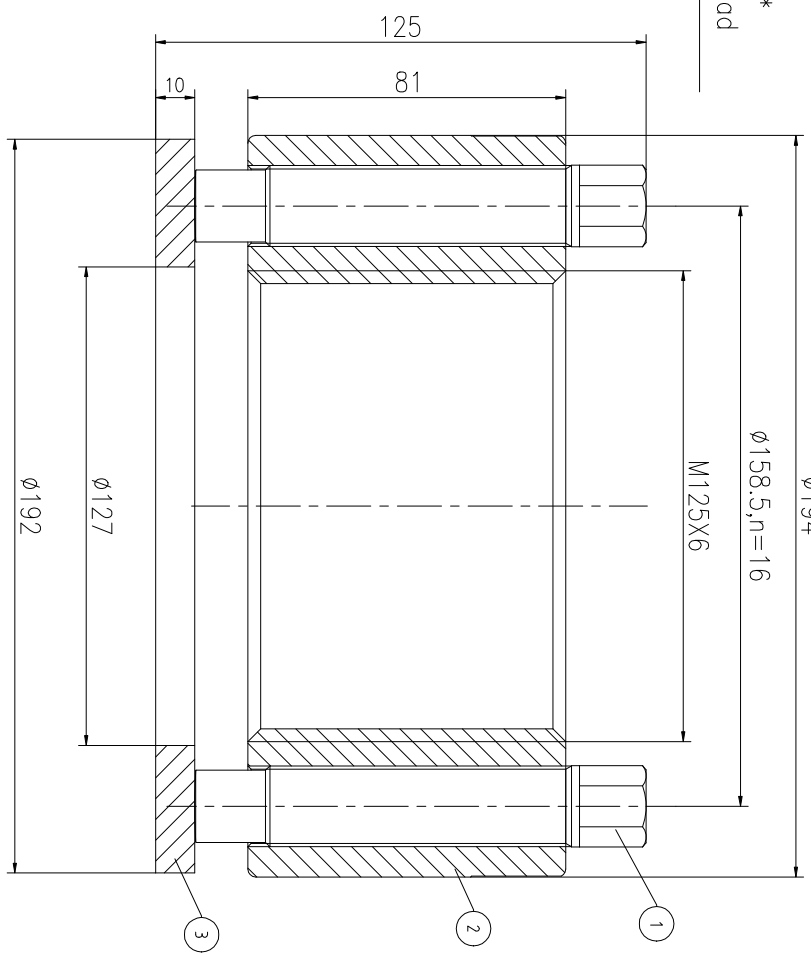
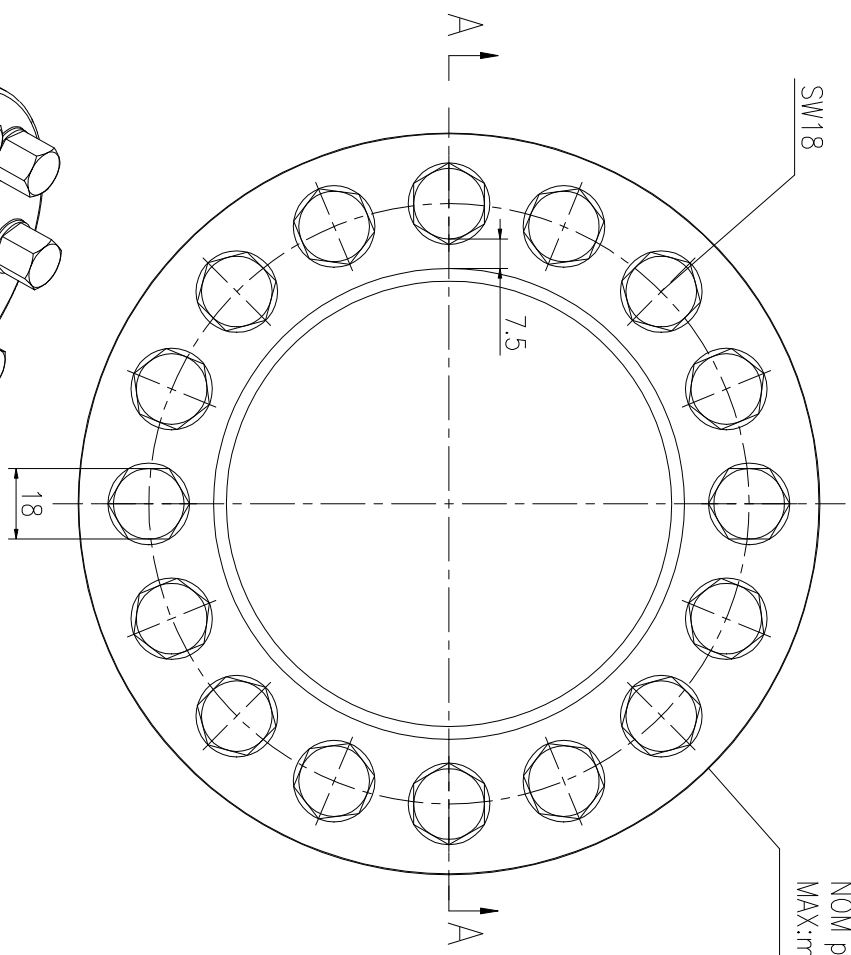

PART	DWG NO.	QTY	DESCRIPTION	MATERIAL	WEIGHT(kg)
1	BAS20.6161151	16	Bolt 13/16-16UN	CNMMo	0.3/pcs
2	AS125681M-1	1	Nut M125X6	CNMMo	8.13
3	AS125681M-3	1	Gasket 127X192X10	CNMMo	1.28

During on-site installation, please adjust the torque in conjunction with the bolt stretching distance. Without our authorization, the drawings shall not be shared with any third party, and we reserve the right to pursue legal liability against those who disclose the drawings to external parties.

NOM TORQUE	674NM	上海康普曼传动机械有限公司	+86 021-61301856
NOM PRELOAD	4200KN	KPM Power Transmission (Shanghai) Co.,Ltd	Liang.Guo@kpmdrive.com.cn
MAX PRELOAD CAPACITY	5600KN	DESIGNED: 2025.11.07	ASM-125X6
LUBRICANT	G-N PLUS	REVIEWED: 2025.11.07	DWG NO.: AS125681M
TEMPERATURE RATING	-25 C~250 C	DRAWN: DATE:	SHEET: 1:1

